

a large area of the lawn around my house. Having a Moto-Mower for cutting the grass, I thought I might be able to use this to get rid of the moles, and I accordingly removed the muffler and connected our ordinary garden hose to it, inserting the free end of the hose into one of the runs of the holes. I started the gasoline engine, giving it a rather rich mixture so that it would smoke, and I found that the fumes were carried all over the yard through the runs made by the moles, coming out in places forty or fifty feet from the point where the hose was inserted into the runs. The following day I took an ordinary lawn roller and rolled the runs back into place, and I have never seen a mole in my yard since. I think that any gasoline engine or automobile which could run near enough to the location would answer the purpose. I feel sure this method will get rid of moles with the least trouble."—*I. H. Chahoon, Indole Golf Club, Au Sable Forks, N. Y.*

Steel Flag Pole of English Manufacture

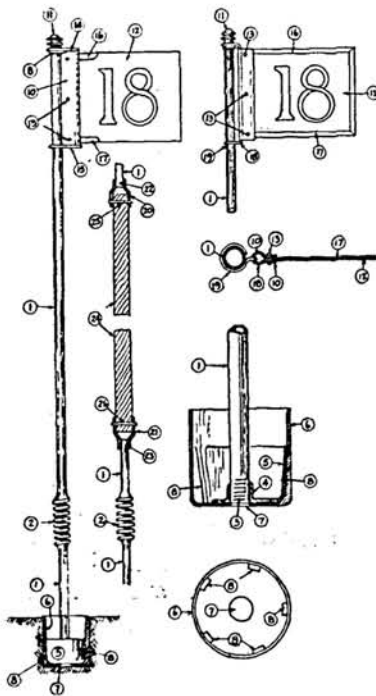

The hole tin and stake cone are malleable cast, the former fitted with 5 taper ribs and the latter tapered in conformity to the ribs in the hole tin and having a round base. The stake is a steel tube of $\frac{3}{4}$, $\frac{1}{2}$, or $\frac{3}{8}$ inch outside diameter. The spring is spring steel wire hardened after welding to steel tube. The flag holder is brass. The flag material is self-colored celluloid, red or white, numbered on both sides.

The special features claimed are that the stake is self-centering, the hole edge protected from damage, and the flag with full rotary motion, extended in all weathers, clearly visible at 500 yards, always clean, no frayed edges, and easily renewed.

Some U. S. Golf Association Decisions on the Rules of Golf

In a medal competition, A holes out leaving his ball in the hole. B putts, holes out, and, of course, as A's ball is in the hole, necessarily B's ball strikes A's. Should B be penalized one stroke under the rule which says, "In medal play, if your putt strikes your fellow player's ball, you are penalized one stroke?"

(Decision) No penalty attaches to B, as A's ball was no longer in play.

In a match play competition, a player playing within 20 yards of the

hole plays his shot without having the flag stick removed and the ball strikes the flag stick. What is the penalty?

(Decision) In a match play, either player may have the flag stick removed at any time. Failure to do this by a player does not penalize his opponent if he should happen to strike the flag stick. Therefore there is no penalty.

Under Rule 12, Section 4, there is a footnote as follows: "A mole-hill or mole-track may be removed from the fair green in any way which will not unnecessarily interfere with the surface of the green." Does this mean that the mole-track may be pressed down level with the fair green by means of the foot? Also, if so, what would the ruling be in case a ball lying on a slope were supported by a mole-track and rolled forward toward the putting green after the track had been pressed down?

(Decision) A mole-hill is a "loose impediment" and can be removed or lifted in accordance with Rule 12 or Rule 28 (1) without penalty as long as the ball is not moved. A mole-hill is however "damage caused to the course by animals," for which it is advisable, where these obstructions are common, to frame a local rule. Under the rules of golf a mole-hill may be removed only by hand, as it is not included among specified "loose impediments" under Rule 28 (2) which may be scraped aside with a club. It is not the custom, in treating a situation of this character, to press down with the foot. Our advice is to cover such cases by having a local rule for dropping the ball without penalty.

White Clover

There is general agreement among golfers that white clover is not a desirable constituent of putting green turf. Fortunately this plant will disappear with the continuous use of ammonium sulfate or ammonium phosphate.

As regards fairways there is no unanimity of opinion on white clover. British tradition is to the effect that white clover mashes under the foot and is slippery. This may be true for Britain, but certainly has little validity in America. It may be that very lush clover is slippery—but such growth on golf courses in America is exceptional at least. More worthy of consideration is the fact that white clover grows more rapidly than grass and gives an uneven appearance to the turf. Furthermore the lie of the ball in clover is not as good as that on grass.

There is another consideration of importance. Even if no white clover seed is sown the plant promptly invades fairways everywhere in the North. This propensity of the plant led the Indians in the early days to call it "white man's foot grass," as they said it sprang up everywhere the white man trod. To control white clover on the fairway as it can be on the putting greens would be decidedly expensive. Furthermore, white clover is certainly at least as much of an asset as a liability on poor soil and especially on sandy soil. Indeed its virtues are such on poor soils that it is desirable to sow some clover seed in the fairway mixture.

British golfers have given white clover a bad name and we have more or less unconsciously accepted their prejudice. The merits of white clover under American conditions need to be evaluated altogether apart from British opinion. A careful study of the plant on American fairways will, we are sure, convince most golfers that its merits far outweigh its faults. In any case we shall always have it with us unless it is kept under check at high expense.